

Communication Interface Module Replacement

Removal Procedure

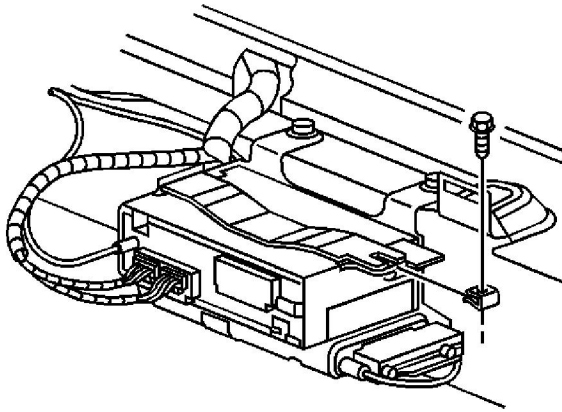

Important: The vehicle communication interface module (VCIM) has a specific set of unique numbers that tie the module to each vehicle. These numbers, the 10-digit station identification and the 11-digit electronic serial number, are used by the National Cellular Network and OnStar® to identify the specific vehicle. Because these numbers are tied to the vehicle identification number of the vehicle, you must never exchange these parts with those of another vehicle.

1. Remove the windshield garnish molding. Refer to [Windshield Pillar Garnish Molding Replacement](#) in Interior Trim.
2. Remove the upper trim pad. Refer to [Instrument Panel Upper Trim Pad Replacement](#) in Instrument Panel, Gages and Console.
3. Remove the bolt holding the locking strap which secures the VCIM to the bracket.
4. Disconnect the electrical connectors.
5. Disconnect the cell antenna coaxial cable from the VCIM.

Important: Return the old VCIM for core credit.

6. Remove the VCIM from the bracket and from the vehicle.

Installation Procedure

1. When replacing a VCIM, record the 11-digit electronic serial number (ESN) and the 10-digit station identification (STID) number from the label on the new VCIM.

Notice: Refer to [Fastener Notice](#) in the Preface section.

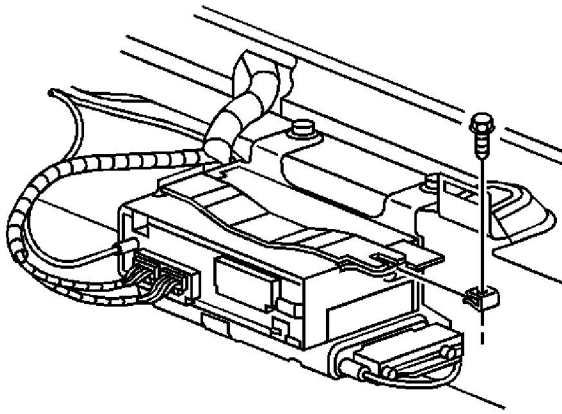

2. Install the VCM to the bracket using the clip strap and tighten the bolt.

Tighten

Tighten the bolt to 10 N·m (89 lb in).

Notice: In order to avoid damage to the circuit board, do NOT over-tighten the thumb screws. Using your fingers, apply only a light pressure.

3. Connect the electrical connectors.

Tighten

Tighten the module thumb screw to a maximum of 0.2 N·m (2 lb in).

4. Connect the cell antenna coaxial cable to the VCIM.
5. Install the upper trim pad. Refer to [Instrument Panel Upper Trim Pad Replacement](#) in Instrument Panel, Gages and Console.
6. Install the windshield garnish molding. Refer to [Windshield Pillar Garnish Molding Replacement](#) in Interior Trim.

Important: After replacing the vehicle communication interface module, you must configure the OnStar® system. Failure to configure the system will result in an additional customer visit for repair. In addition, pressing and holding the white dot button on the keypad will NOT reset this version of the OnStar® system. This action will cause a DTC to set.

7. Reconfigure the OnStar® system. Refer to [OnStar Reconfiguration](#) .